

**COLOUR TELEVISION**

**SANYO**

CHASSIS SERIES **EB6**

MODEL NUMBER **CE21DN7-C**

SERVICE REF.NO. **CE21DN7-C-00**

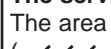
**The service Precaution:**  
 The area enclosed by this line (  ) is directly connected with AC mains voltage. When servicing the area, connect an isolating transformer between TV receiver and AC line to eliminate hazard of electric shock.

**Product safety notice:**  
 Product safety should be considered when a component replacement is made in any area of a receiver. Components indicated by a mark  in this circuit diagram show components whose values have special significance to product safety. It is particularly recommended that only parts specified on the part service manual be used for components replacement pointed out by the mark.

- Circuit diagram notes :**
1. All resistance values are in ohms, K=1,000, M=1,000,000.
  2. All resistance rated wattages are 1/6W unless otherwise noted.
  3. Excepting electrolytic capacitors, all capacitance values of less than 1 are expressed in  $\mu\text{F}$  and more than 1 are pF.
  4. All capacitance rated voltages are 50V unless otherwise noted.
  5. All inductance values are in  $\mu\text{H}$ .
  6. Voltage readings taken a digital voltmeter are from point indicated chassis ground. Voltage readings taken by using a colour bar signal are with all controls at normal position. Some voltages may vary with signal strength.
  7. Waveforms were taken with colour bar and controls adjusted for normal picture. Waveforms were taken by using a wide band oscilloscope and a low capacity probe.

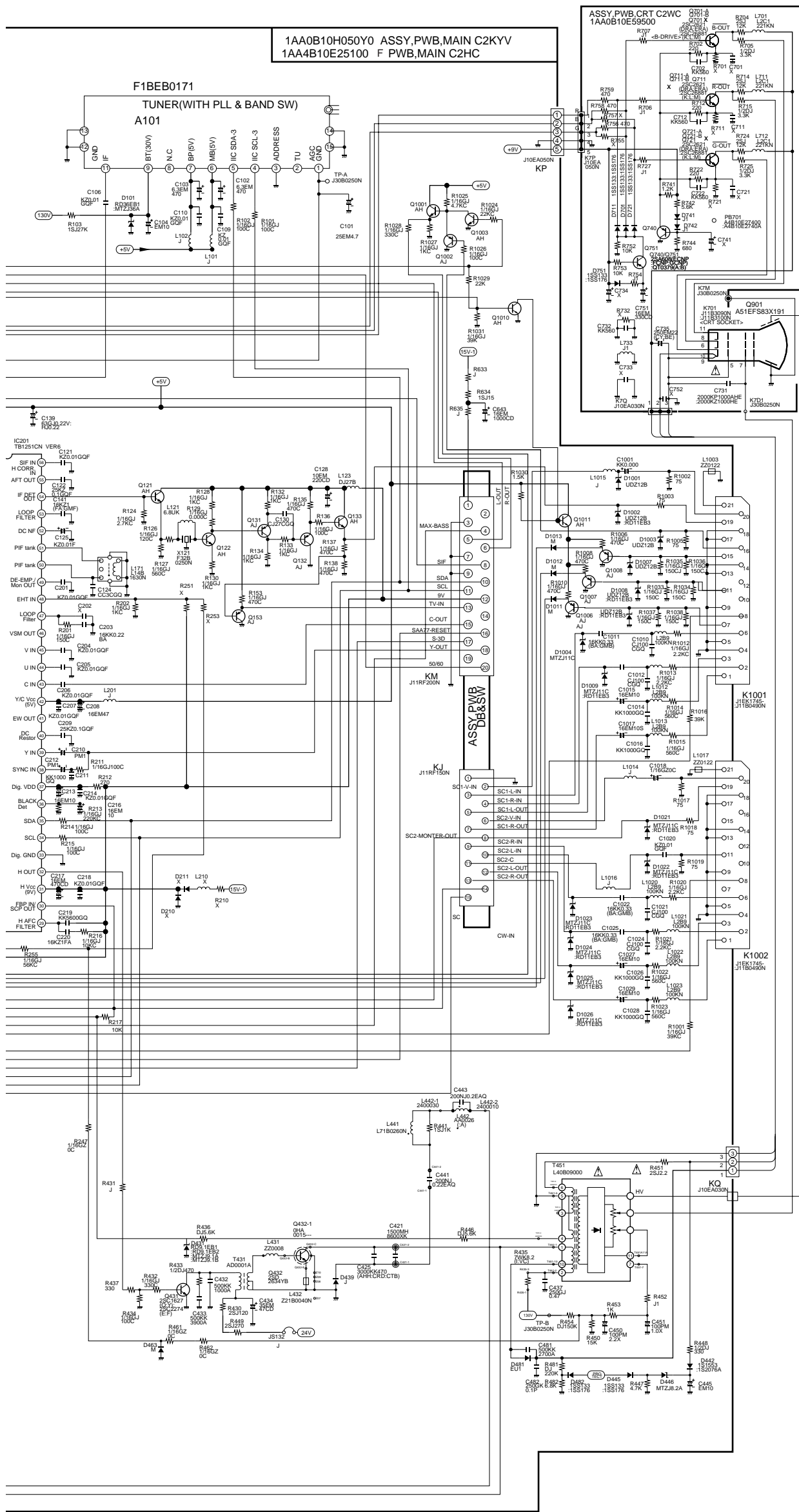

8. This circuit diagram covers a basic or representative chassis only. There may be some components or partial circuit differences between the actual chassis and the circuit diagram.
9. ■ Diode 1S1555 may be replaced with 1S2473, 1S2076 or DS472 unless otherwise noted.
- Transistor 2SC536(Q,R,S), 2SC1740(Q,R,S), 2SC945A(Q,R,P) or 2SC1815(G,O,Y) unless otherwise noted.
- Transistor 2SA608(E,F) may be replaced with 2SA933(Q,R), 2SA564(QA,RA), or 2SA1015(O,Y) unless otherwise noted.

**Expression of capacitance and resistance in circuit diagram.**

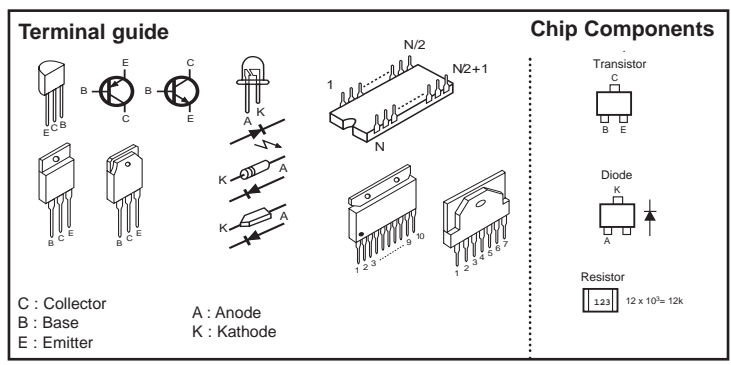
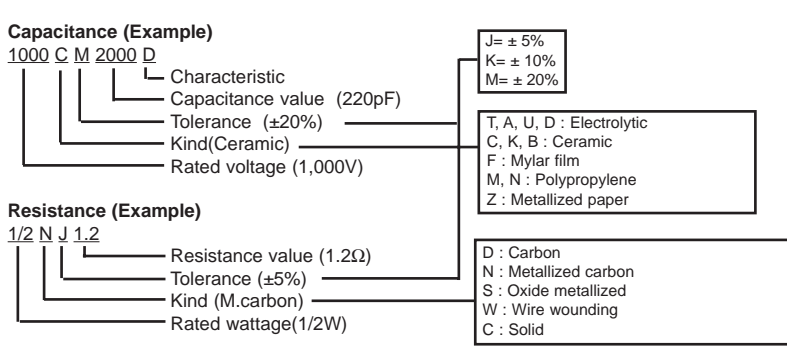

ASSY,PWB,NICAM&SW C2KRV (1AA0B10H043L0)  
 PWB,NICAM&SW C2HA (1AA4B10E27900)

TV	A	B
SC1	L	L
SC2	L	L

○ A4B10E2790A

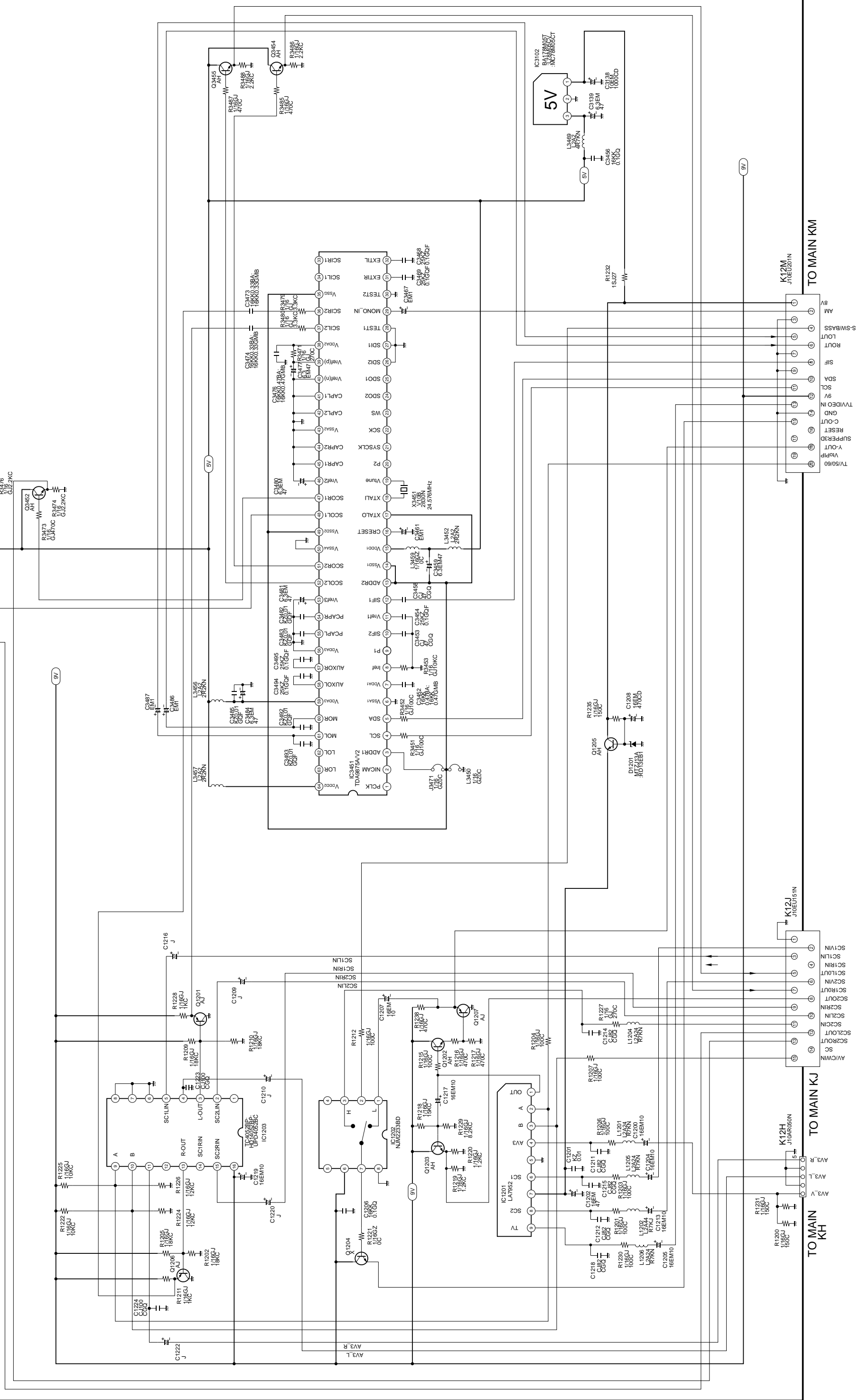

# MAIN BOARD

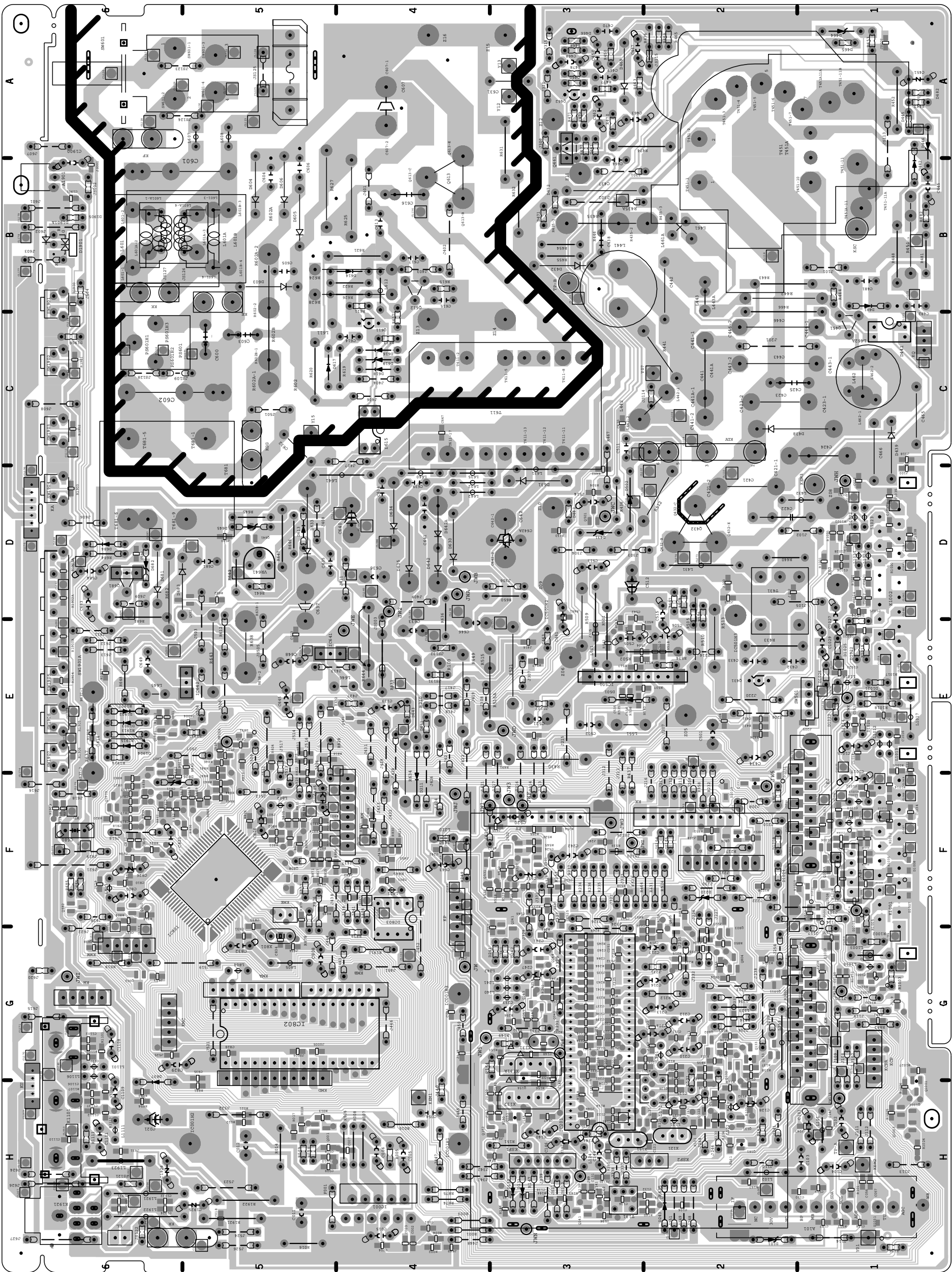

# MAIN BOARD

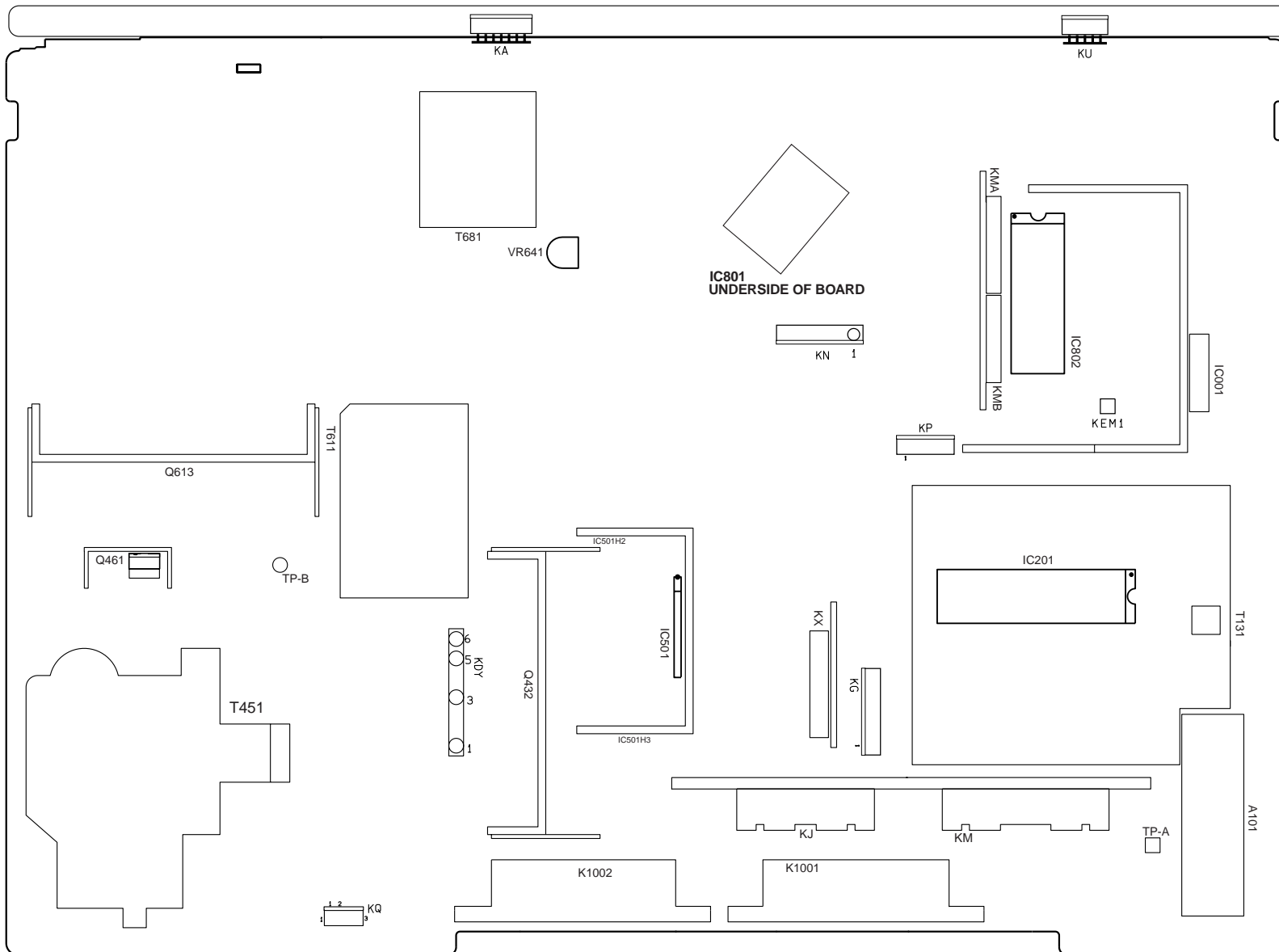

## BLOCK DIAGRAM (OUTLINE)

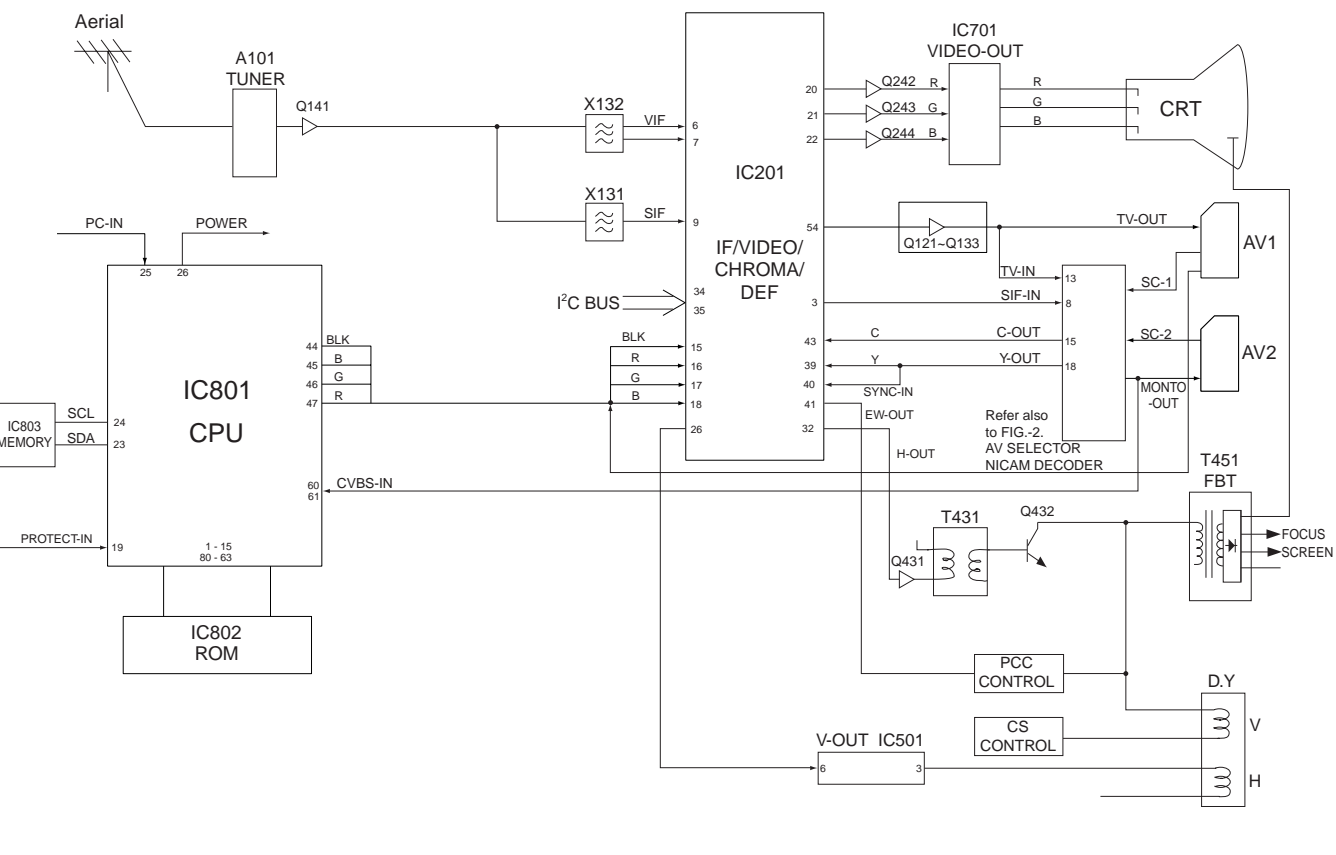

## BLOCK DIAGRAM (SYSTEM CONTROL)

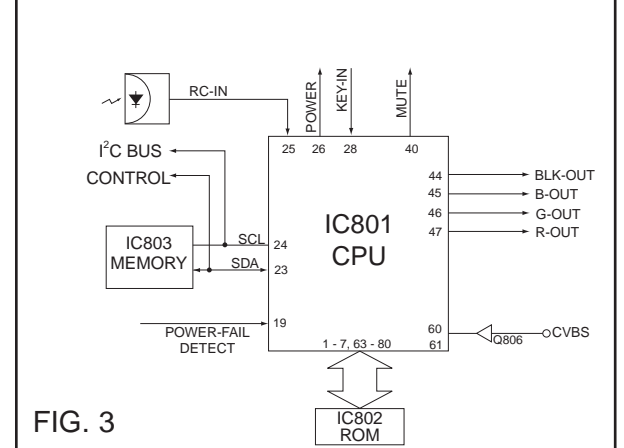

FIG. 3

## BLOCK DIAGRAM (AV SELECTOR/ NICAM DECODER)

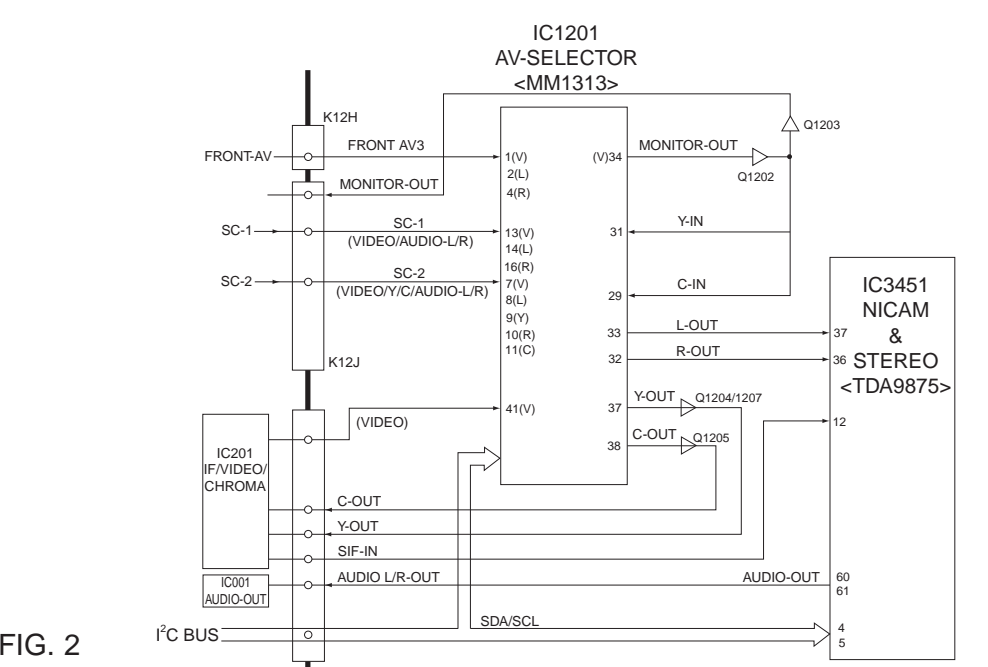

FIG. 2

## OPTION SETTING

### [After replacing the Memory IC (IC803)]

The memory IC, IC803, stores the option data of TV set and service adjustments data for each circuit, therefore, when the memory IC is replaced, it should be performed following setting and SERVICE ADJUSTMENT on next page.

### To enter to the Option Mode

+ Press and hold the **F/OK** button on the remote control and **P▼** button on the front panel of the TV. The option window will appear on the screen. Enter the settings as shown below for the correct SERVICE REF. NO..

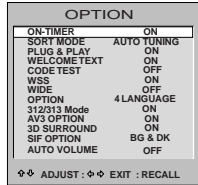

SERVICE REF. NO. CE21DN7-C-00

### To set the option mode

+ Highlight the desired option item by using the **P▲** or **P▼** button.  
+ To switch the option mode, use the **Volume - (LEFT)** or **Volume + (RIGHT)** button.  
+ The data which is set in the option mode is stored into the memory IC automatically.

Following table shows the available option items and default setting mode.

Option Mode	Mode	Description & Note
ON-TIMER	ON or OFF	On-timer available, default OFF
SORT MODE	AUTO TUNE/SORT or AUTO TUNING or ATS EURO PLUS	Tuning mode, default AUTO TUNING*
PLUG & PLAY	ON or OFF	Plug & Play mode, default ON
WELCOME TEXT	ON or OFF	Display message when first set up, default ON
CODE TEST	OFF or ON	For factory use, default OFF
WSS	ON or OFF	Wide Screen Signaling available, default ON
WIDE	ON or OFF	Wide mode, default ON
OPTION	4 LANGUAGE or ALL LANGUAGE	Destination option, default 4 LANGUAGE
312/313 Mode	ON or OFF	Teletext mode, default OFF
AV3 OPTION	ON or OFF	Front AV disable, default ON
SIF OPTION	ON or OFF	Television system, default BG I L/L'

### Exit from the Service Mode

+ Press the **RECALL** button.

## SERVICE ADJUSTMENTS

Note: Some items of the service adjustments for this chassis are controlled by the CPU, IC801, and the adjustments are carried out by using the RC handset.

### [After replacing the Memory IC (IC803)]

The memory IC, IC803, stores the service adjustments data for each circuit, therefore, when the memory IC is replaced, it should be performed "OPTION SETTING" on previous page and the following adjustments, refer to further adjustment on page 14.

### ADJUSTABLE SERVICE ADJUSTMENT

#### REGULAR

Item No.	OSD	Description
1	AGC	AGC Adjustment
2	CUT	Cut-Off Drive Adjustment
3	GRY	G-Drive Adjustment
4	GRY	B-Drive Adjustment
7	HBP	H-Blanking Phase Adjustment
8	OSD	OSD Positioning Adjustment

#### WIDE

Item No.	OSD	Description
1	P V-P	Vertical Centre Adjustment
2	P H-P	Horizontal Centre Adjustment
5	P V-S	Vertical Size Adjustment
6	P H-S	Horizontal Size Adjustment
7	P PCC	Pcc Adjustment
8	P TRP	Trapezoid Distortion Adjustment
10	P CNR	Corner Adjustment

### IMPORTANT NOTICE

Do not attempt to adjust service adjustments not listed on the above otherwise it may cause loss of performance and product safety.

### To enter to the Service Mode

+ Press and hold the **GREEN** button on the remote control and then press the **P▼** button inside of the door. The adjustment window will appear on the screen.

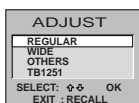

### To select the mode and service item and change data value

+ Highlight the desired adjustment mode by using the **P▲** or **P▼** button and then press the **F/OK** button.  
+ To select the adjustment item, use the **P▲** or **P▼** button.  
+ To change the service data, use the **Volume - (LEFT)** or **Volume + (RIGHT)** button.  
+ The data which is set in the service mode is stored into the memory IC automatically.

#### REGULAR mode

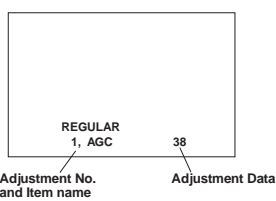

#### WIDE mode

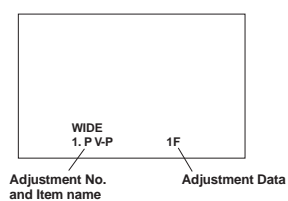

### Exit from the Service Mode

+ Press the **RECALL** button or turn off the TV set by using the Mains switch.

### INITIALISATION OF MEMORY IC

To initialise the memory IC (IC803), press and hold the **NORMAL** button on the remote control and then press the **P▲** button on the front panel of the TV set, and then turn the Mains switch Off and On. Now the initialisation is completed.

When initialised the memory IC, all of the setting data (option data and service adjustment data) stored in the IC are reset to the default value. So it is necessary to set the option settings and readjust the service adjustments listed on left page.

## ADJUSTMENTS

### IMPORTANT NOTICE

Do not attempt to adjust the following service adjustments except when adjustments are required in servicing otherwise it may cause loss of performance and product safety.

#### + B VOLTAGE ADJUSTMENT

1. Receive white raster pattern.
2. Set controls to normal.
3. Connect digital voltmeter to test point TP-B and GND.
4. Adjust voltage to 130 ±0.5V using VR641 (21" model). Adjust voltage to 150 ±0.5V using VR641 (25" model). Adjust voltage to 150 ±0.5V using VR641 (28" model).

#### AGC ADJUSTMENT

1. Input and tune a VHF RF signal which has the strongest signal strength.
2. Connect digital voltmeter to test point TP-A and GND.
3. Enter to the service mode and select mode "REGULAR", and select item no.1 "REGULAR 1, AGC".
4. Press the **LEVEL+** or **LEVEL -** button to adjust voltage to be 3.2Vdc.

#### FOCUS ADJUSTMENT

By using FOCUS VR, adjust focus control for well defined scanning lines.

#### GREY SCALE ADJUSTMENT

##### SCREEN ADJUSTMENT

1. Receive black & white pattern.
2. Enter to the service mode and select mode "REGULAR", and select item no. 2 "REGULAR 2, CUT". The horizontal line will appear on the screen.
3. Set the SCREEN VR for one colour to be just visible.
4. Using the numeric buttons shown set each colour to minimum by decreasing to the point where any further decrease resets the adjustment to maximum value.

##### BIAS ADJUSTMENT

5. By using the buttons 1, 2, 4, 5, 7, 8 on the remote control, adjust the line to be white.

The key allocation is as follows;

#### Button No. Operation

- |   |                |
|---|----------------|
| 1 | Increase Red   |
| 2 | Decrease Red   |
| 4 | Increase Green |
| 5 | Decrease Green |
| 7 | Increase Blue  |
| 8 | Decrease Blue  |

#### DRIVE ADJUSTMENT

6. Select item no.3 "REGULAR 3, GRY" (G-Drive) or 4 "REGULAR 4, GRY" (B-Drive) and adjust both initially to 3F.
7. Change data value of each item by using **LEVEL +** or **LEVEL -** button to obtain the proper white balance.

#### PCC ADJUSTMENT

##### PCC ADJUSTMENT

1. Receive cross hatch pattern and set screen mode to "FULL".
2. Enter to the service mode and select mode "WIDE", and select item no. 7 "WIDE 7,P PCC".
3. Press the **LEVEL+** or **LEVEL -** button to adjust the vertical line to be straight.

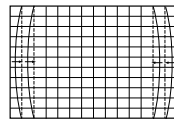

#### TRAPEZOID ADJUSTMENT

1. Receive cross hatch pattern and set screen mode to "FULL".
2. Enter to the service mode and select mode "WIDE", and select item no. 8 "WIDE 8,P TRP".
3. Press the **LEVEL+** or **LEVEL -** button to correct the trapezoid distortion of the vertical line.

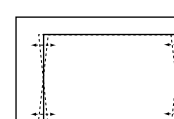

#### VERTICAL HEIGHT ADJUSTMENT

1. Tune the receiver to a circular pattern.
2. Enter to the service mode and select mode "WIDE", and select item no. 5 "WIDE 5,P V-S".
3. Press the **LEVEL+** or **LEVEL -** button to adjust the vertical height.

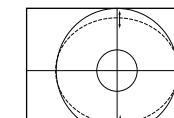

#### H-BLANK ADJUSTMENT

1. Tune the receiver to a circular pattern.
2. Enter to the service mode and select mode "REGULAR", and select item no. 7 "REGULAR 7,HBF".
3. Press the **LEVEL+** or **LEVEL -** button to adjust the centre of picture image to be screen centre.

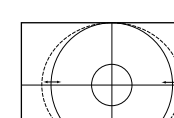

#### OSD POSITIONING ADJUSTMENT

1. Tune the receiver to a circular pattern.
2. Enter to the service mode and select mode "REGULAR", and select item no. 8 "REGULAR 8 OSD". The OSD test bar will appear on the top of screen.
3. Press the **LEVEL+** or **LEVEL -** button to adjust proper OSD positioning.

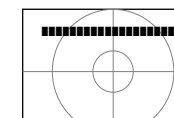

#### CORNER ADJUSTMENT

1. Tune the receiver to a circular pattern.
2. Enter to the service mode and select mode "WIDE", and select item no. 10 "WIDE 10,P CNR".
3. Press the **LEVEL+** or **LEVEL -** button to correct the distortion of the vertical line around the corners.

#### HORIZONTAL ADJUSTMENT

##### HORIZONTAL CENTRING ADJUSTMENT

1. Tune the receiver to a circular pattern.
2. Enter to the service mode and select mode "WIDE", and select item no. 2 "WIDE 2,P H-P".
3. Press the **LEVEL+** or **LEVEL -** button to adjust the horizontal centre.

##### HORIZONTAL WIDTH ADJUSTMENT

1. Tune the receiver to a circular pattern.
2. Enter to the service mode and select mode "WIDE", and select item 6 "WIDE 6,P H-W".
3. Press the **LEVEL+** or **LEVEL -** button to adjust the horizontal width.

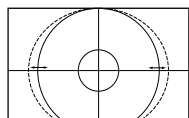

#### HIGH-VOLTAGE CONFIRMATION

1. Tune the receiver to a circular pattern.
2. Set controls to normal.
3. Connect high-voltage meter to the anode of CRT and GND.
4. Confirm that voltage is 38.0±1.0kV for 21" model. Confirm that voltage is 29.0±1.0kV for 25" model. Confirm that voltage is 29.0±1.0kV for 28" model.

#### VERTICAL ADJUSTMENT

##### VERTICAL CENTRING ADJUSTMENT

1. Tune the receiver to a circular pattern.
2. Enter to the service mode and select mode "WIDE", and select item no. 1 "WIDE 1,P V-P".
3. Press the **LEVEL+** or **LEVEL -** button to adjust the vertical centre.

## CPU PORT FUNCTIONS

Pin No.	Function Name	Function	IN/OUT
1	MMU0	External memory 0	OUT
2	MMU3	External memory 3	OUT
3	ADDR10	Address bus 10	OUT
4	DSN	Data Strobe	
5	ADDR11	Address bus 11	OUT
6	ADDR9	Address bus 9	OUT
7	ADDR8	Address bus 8	OUT
8	R_WN	Read Write Strobe	
9	GND		
10	VDD	Power Supply	IN
11	OSC-IN	Clock Input	IN
12	OSC-OUT	Clock Output	OUT
13	ADDR13	Address bus 13	OUT
14	ADDR14	Address bus 14	OUT
15	MMU1	External memory 1	OUT
16	MMU2	External memory 2	OUT
17	MMU4	External memory 4	OUT
18	MMU5	External memory 5	OUT
19	P3.7/CSO	Protect - Power failure detect input	IN
20	P3.6/ASN	Dolby CLK(L/L)	OUT
21	P3.5	Dolby S0(Super 3D)	OUT
22	P3.4	PITARR1 switch	OUT
23	P5.1	IIC BUS SDA	IN/OUT
24	P5.0	IIC BUS SCL	OUT
25	P2.0	Remote Control Signal Input	IN
26	P2.3	Power Relay & LED Drive On: L	OUT
27	P2.4	SUB CPU SO	OUT
28	P0.2	Key switch input	IN
29	P0.1	SUB CPU CLK	OUT
30	P0.0	SUB CPU SI	IN
31	P4.7	THRESHOLD switch	OUT
32	P4.6	JIMAKU(Caption) switch	OUT
33	P4.5	On-Timer LED Drive ON: L	OUT
34	VDD		IN
35	GND		
36	P2.1	AV1 Scart function input	IN
37	P2.2	AV2 Scart function input	IN
38	P2.5	RF AGC input	IN
39	P4.4	H-Blank On/Off	OUT
40	P4.3	AMP Mute Mute On: H	OUT
41	P4.2	Dolby RQ	OUT
42	P4.1	H-Blank Phase	OUT
43	P4.0	50/60Hz output 50Hz: H	OUT
44	FB	BLK Output for OSD (Active H)	OUT
45	B	Blue Output for OSD (Active H)	OUT
46	G	Green Output for OSD (Active H)	OUT
47	R	Red Output for OSD (Active H)	OUT
48	V-SYNC	V-Sync Input (Active H)	IN
49	H-SYNC	H-Sync Input (Active H)	IN
50	WSCR	VPS/WSS Slicer Line PLL	
51	WSCF	VPS/WSS Slicer Line PLL	
52	VDD-A	Analogue Power Supply	IN
53	PXFEM	Pixel Frequency Multiplier	
54	RESET	Reset Input (Active L)	IN
55	MCFM	Pixel Frequency Multiplier	
56	JTRSTO		
57	TXCF		
58	CVBS0		
59	TEST0		
60	CVBS1	Video signal Input	IN
61	CVBS2	Video Signal Input	IN
62	GND-A		
63	DAT3	Data bus 3	IN
64	DAT4	Data bus 4	IN
65	DAT5	Data bus 5	IN
66	DAT6	Data bus 6	IN
67	DAT7	Data bus 7	IN
68	DAT2	Data bus 2	IN
69	DAT1	Data bus 1	IN
70	DAT0	Data bus 0	IN
71	ADDR0	Address bus 0	OUT
72	ADDR1	Address bus 1	OUT
73	ADDR2	Address bus 2	OUT
74	ADDR3	Address bus 3	OUT
75	ADDR4	Address bus 4	OUT
76	ADDR5	Address bus 5	OUT
77	ADDR6	Address bus 6	OUT
78	ADDR7	Address bus 7	OUT
79	ADDR12	Address bus 12	OUT
80	ADDR15	Address bus 15	OUT

## CRT BOARD

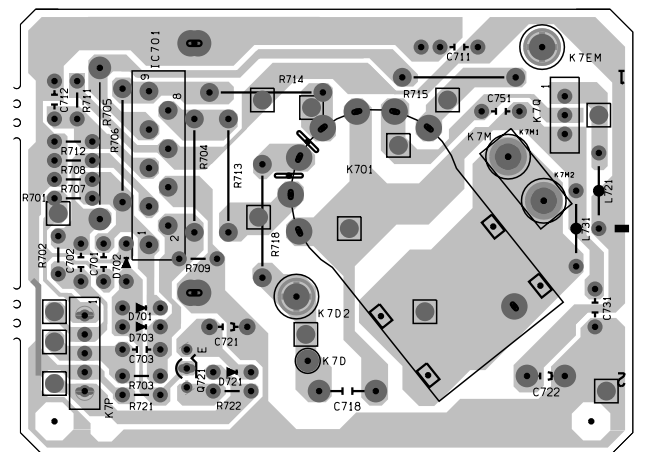

## A2 STEREO BOARD

